

**PreBeam® 0,15 Alu / 1,2 Lam**

Specific mass: 179 g/m (+/- 5 %)  
 Material: AW 1200  
 Epoxy-laminate  
 PU  
 Length: 2950 mm (+/- 1 %)  
 Corrugating modulus: 2,5 mm  
 Aluminium thickness: 0,15 mm  
 Surface aluminium: non-treated  
 Surface laminate: brushed  
 Max. temp. (continuous): 70 °C  
 Min. temperature: - 10 °C  
 Dimensions: 28x56 mm  
 Characteristics: Multipurpose profile for  
 low-weight applications  
 extra strength, water resistant  
 Cutting: by saw

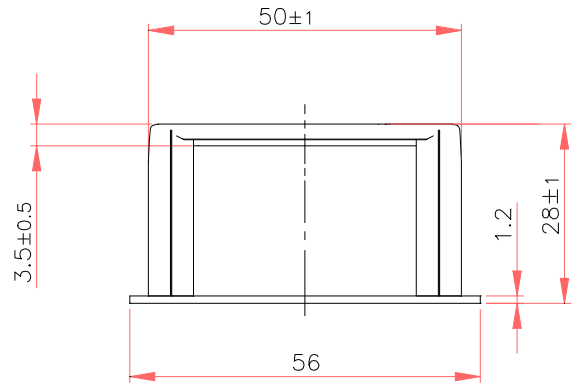

Radial shapes:

Min. outer radie: 200 mm  
 Min. inner radie: 100 mm

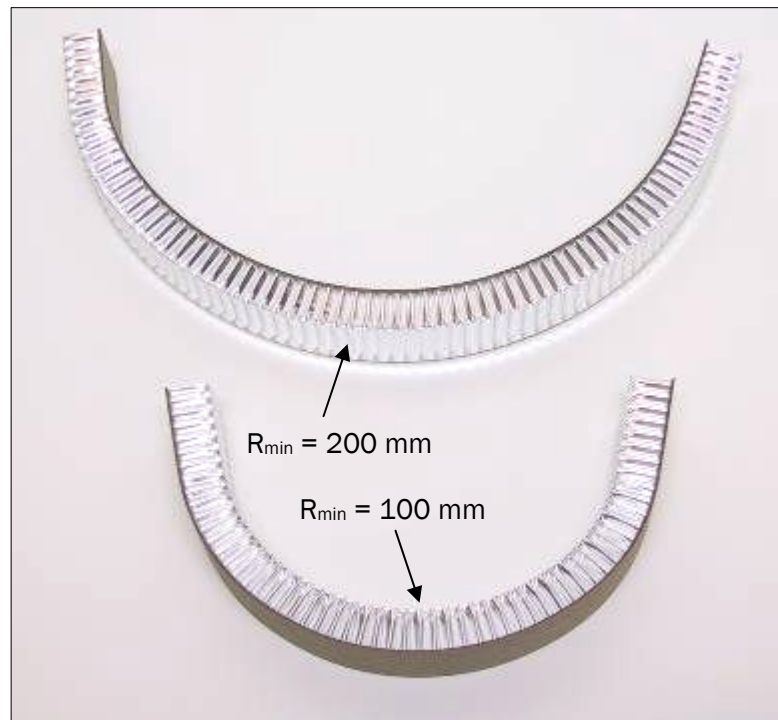

Storage: Temperature: Room temperature  
 Placement: Linear straight lengths on even surface  
 RH 20% - 70 %  
 Avoid direct sunlight

3-point bending

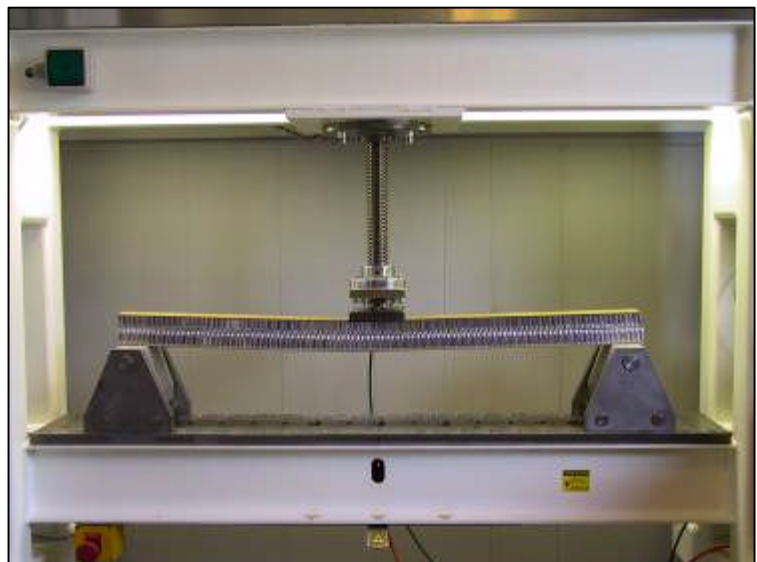
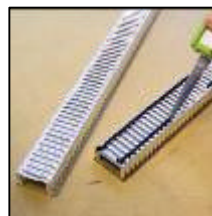
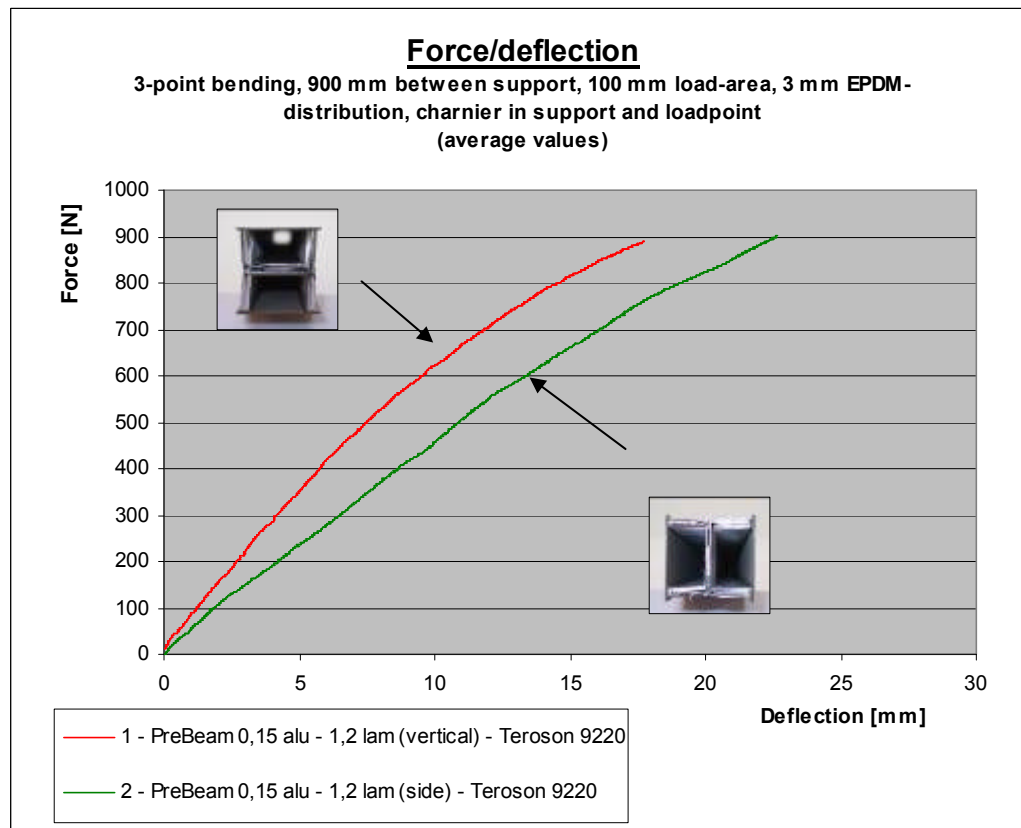

Conditions:

Room: 17 degrees C, 52 % RH

Speed: 11 mm/min

*The technical information and data provided above should be considered representative or typical only, and should not be used for specification purposes. Any further construction should be based on individual studies and testing with the materials involved.*